

Worm Gear Reducers

6mm Input Shaft Double Sided • 8mm Output Bore 30mm
Centre Distance • T_{2max} 7Nm – 9Nm • **10:1 - 120:1**

Worm Gear Rotation Direction.

RH-Right Hand

When input rotation is clockwise , output gear is pulled towards input.

When input is counter-clockwise , output gear is pushed away from input.

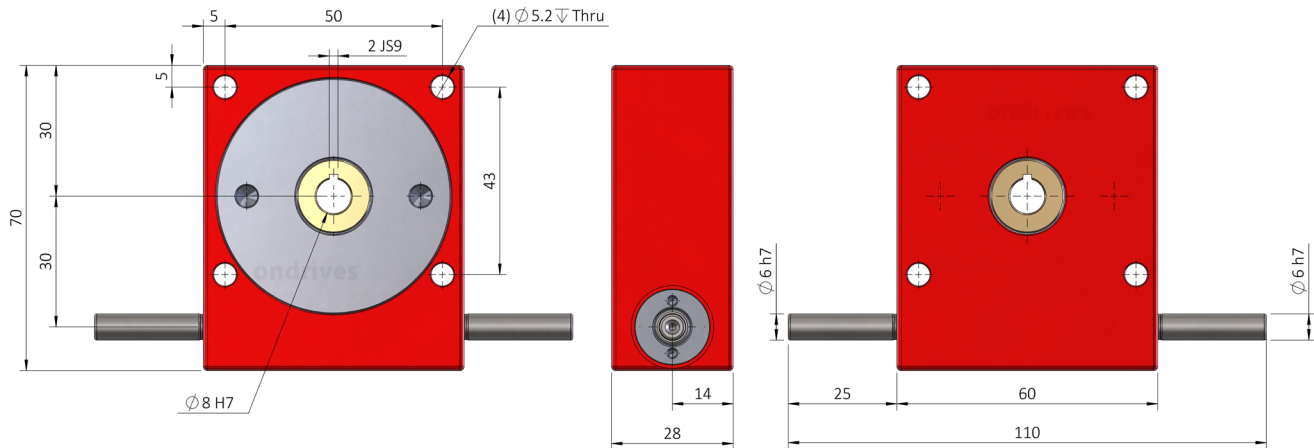
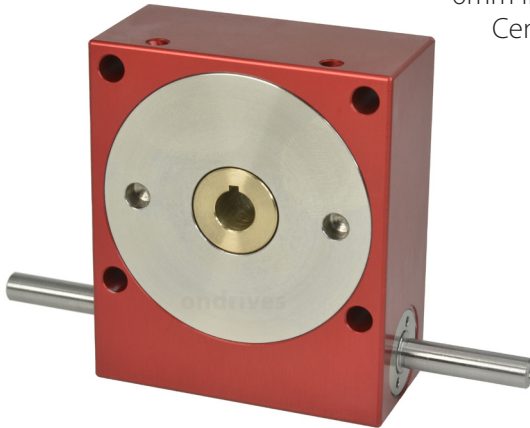

Output Backlash j	Part Numbers	Output Backlash j AR	Gear Ratio i	Efficiency ηz	Lead Direction	Reflected Inertia at Input
≤0.50°	Output Backlash j A	≤0.066°		n1nom		kg·m ²
P30-10	P30-10A	P30-10AR	10:1	90%	Right Hand	8.43x10 ⁻⁷
P30-12	P30-12A	P30-12AR	12:1	88%	Right Hand	7.55x10 ⁻⁷
P30-15	P30-15A	P30-15AR	15:1	86%	Right Hand	6.92x10 ⁻⁷
P30-20	P30-20A	P30-20AR	20:1	84%	Right Hand	6.43x10 ⁻⁷
P30-30	P30-30A	P30-30AR	30:1	78%	Right Hand	6.08x10 ⁻⁷
P30-60	P30-60A	P30-60AR	60:1	70%	Right Hand	5.87x10 ⁻⁷
P30-120	P30-120A	P30-120AR	120:1	40%	Right Hand	5.72x10 ⁻⁷

Weight: 0.48 kg.
Nom. Input Speed [S1 T₂n] n1nom: 1,000 min⁻¹ (r/min)
Max. Input Speed n1max: 3,000 min⁻¹ (r/min)
Lubrication: Grease Shell Gadus S5 V4P 2.5
Lubrication Temperature: Max. Operating ≈ 60°C
Max. Input Radial Load F_{r1}: 30N.
Max. Output Radial Load F_{r2}: 200N.
Max. Output Axial Load F_{a2}: 120N.

Testing in your application is necessary.
 You will need to assess duty cycles and confirm suitability with your own calculations.
 Figures listed are for guidance only.
 Cooling may be needed dependent on application.

Worm Gear Reducers

6mm Input Shaft Double Sided • 8mm Output Bore 30mm
Centre Distance • T_{2max} 7Nm – 9Nm • **10:1 - 120:1**

P Series Wormwheel Gearboxes

